

DETAIL 1
SCALE: N.T.S

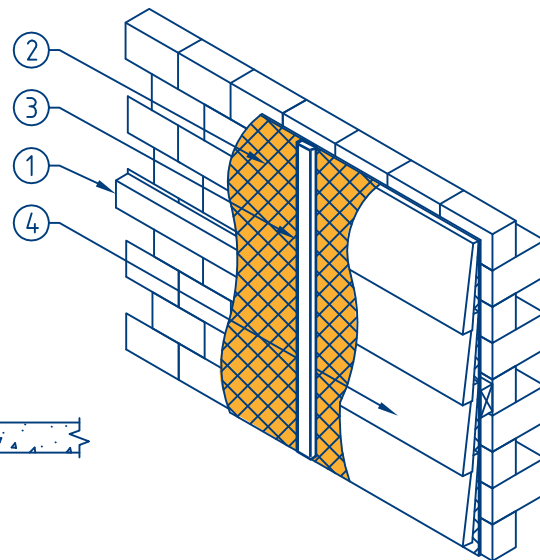

DETAIL 2
SCALE: 1:25

Notes:

The R-values shown are Total R-values for the building element as required by the Energy Provisions of the Building Code of Australia. Air-Cell products are manufactured, tested and packaged in conformance with AS/NZS 4859.1:2002 – Amdt 1.

The contribution of the product Total R-values depends on installation and environmental conditions. The R-value will be reduced in the event of the accumulation of dust on the upward facing surfaces and in those cavities that are ventilated.

Where joints are applicable, apply 150mm overlap (taped or untaped) or butt joint and tape. Application for roll-out for this design profile is horizontal.

Total R-Values

Application	Product	Heat Flow In	Heat Flow Out
Wall	Glareshield®	R _T 1.9	R _T 2.1